

## POS Register Stand Up Display Vacuum Fluorescent Screen VFD Monitor (Model: VFD220A)

### Specifications:

Communication	
Interface:	Serial port (RS-232)
Baud rate:	9600bps
Brightness:	2000cd
Data bit:	8bit
Stop bit:	1bit
Handshake signal:	No
Electrical:	By the power of the host computer DC12 (big 4ps interface)
Display:	VFD Bright blue-green fluorescent display
Display characters:	2 line x 20 characters / line, 40 characters, 5 x 7 Dots
Display area:	160mm(W) x 23.8mm(H)
Character size:	high 11mm x wide 7mm
MTBF:	25,000 hours
Dimensions	
Panel dimensions:	80(H) x 225(W)x37(D) mm
Support dimensions:	Long support: 480mm (Contain base) Short support: 225mm (Contain base) Base dimensions: 185(L) x95(w) x25(H) mm
Pitching move angle:	45°, Can provide comfortable, and adjust the visual Angle
Weight:	1.2Kg (gross)
Environment	
Operating Temp:	-20~70 A18
Storage Temp;	-40~80 A19
Operating Humidity:	10~85%
Storage Humidity:	10~90%
Command Set	
Adopting international standard general command ESC/POS, Its can used in DOS or Windows System Environment, Don't need any driver, Only according to the format serial order set to send data can show content.	
With the function of opening the cash drawer All direction adjustable.	

### Product Details:



# Double Line VFD Customer Display

VFD220A



## Product Picture





## Features

***Simple but not easy***

Double lines 20\*2 characters VFD display;





Support 13 countries languages;

Power may be sourced from system,  
with the bracket and cable kit supplied  
in typical configuration.



360 degree rotation angle;



Pole height is adjustable;

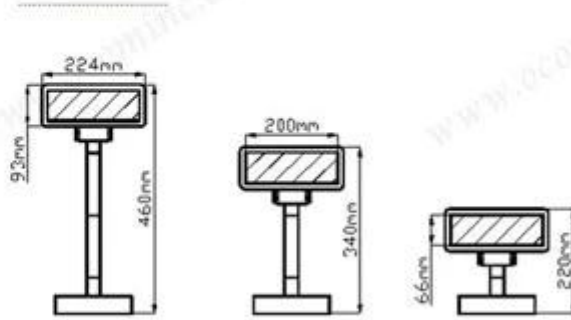

## All-round show





## Application Area

Catering: hotel, restaurant, fast-food restaurant, coffee shop, bakery and cake shop

Retailer: Business Street, boutique, department store, cosmetics shop and high-class barbershop

Recreation: sauna, spa, night club, theme park, casino and point of sales for lottery ticket

Commercial: information management terminals for parking lot, inn, aviation, subway, station and wharf





## Parameter

<b>Communication</b>	
Interface:	Serial port (RS-232)
Baud rate:	9600bps
Brightness:	2000cd
Data bit:	8bit
Stop bit:	1bit
Handshake signal:	No
Electrical:	By the power of the host computer DC12 (big 4ps interface)
Display:	VFD Bright blue-green fluorescent display
Display characters:	2 line x 20 characters / line, 40 characters, 5 x 7 Dots
Display area:	160mm(W) x 23.8mm(H)
Character size:	high 11mm x wide 7mm
MTBF:	25,000 hours
<b>Dimensions</b>	
Panel dimensions:	80(H) x 225(W)x37(D) mm
Support dimensions:	Long support: 480mm (Contain base) Short support: 225mm (Contain base) Base dimensions: 185(L) x95(w) x25(H) mm
Pitching move angle:	45°, Can provide comfortable, and adjust the visual Angle
Weight:	1.2Kg (gross)
<b>Environment</b>	
Operating Temp:	-20~70 A18
Storage Temp:	-40~80 A19
Operating Humidity:	10~85%
Storage Humidity:	10~90%
<b>Command Set</b>	
Adopting international standard general command ESC/POS, Its can used in DOS or Windows System Environment, Don't need any driver, Only according to the format serial order set to send data can show content.	

With the function of opening the cash drawer All direction adjustable.

## Production Line



## Capacity

Verified	Product Name	Production Line Capacity	Actual Units Produced(Previous Year)
✓	Thermal Printer	40,000 Sets / Month	250,000 Sets



✓	Dot Matrix Printer	15,000 Sets / Month	10,000 Sets
✓	Bluetooth Printer	30,000 Sets / Month	20,000 Sets
✓	Barcode Scanner	40,000 Sets / Month	20,000 Sets
✓	POS Machine	5,000 Sets / Month	10,000 Sets
✓	Magnetic Card Reader and Writer	45,000 Sets / Month	50,000 Sets

✓ Indicates information has been verified onsite by TUV on 2013.7.15

## Quality Assurance

OCOM is dedicated to providing most cost-effective products and services with highest quality that will meet customers' satisfaction.



Since the establishment, OCOM has been sticking strictly to the standard and requirements of ISO9001: 2000 in the processes of research, design, manufacturing and services. OCOM's products have passed CE, FCC, TUV, RoHS and other certifications.

We make strictly IQC, IPQC and OQC inspection per industrial standard. All the products must pass 24-48 hours aging test before shipment. Some designated models can have as long as 24 months warranty.

## Test Equipments

Verified	Machine Name	Brand & Model No.	Quantity
✓	Ageing Tester	No Information	6
✓	Withstand Voltage Tester	CC2670A	1
✓	Oscilloscope	TBS1102	1

✓	DC Power Supply	PS-305DM	6
✓	Digital Torque Meter	HP100	1
✓	Calliper	GUANGLU	2
✓	Multi-meter	VC890D	7
✓	Test Computer	No Information	13

✓ Indicates information has been verified onsite by TUV on 2013.7.15

## Certifications



## Packing and Shipment



## Payment



## Customers Reference

Over the years, OCOM keep efforts on marking "OCOM" as an internationally recognized brand, and we have established goods relationship with our customers and have friendly communication with each other.





## Why you choose us?



## Company Profile



# This Assessed Supplier Has Been Independently Verified

Build Your Growth On Trust



**TÜVRheinland**  
Precisely Right.



OCOM Technologies Limited, founded in 2007, is one of the leading suppliers of POS and Auto-ID related products from China.

OCOM's products portfolio covers Thermal Printer, Dot Matrix Printer, Barcode Printer, Barcode Scanner, Magnetic Card Reader, POS Terminal, and POS peripherals. Our products have passed CE, FCC, RoHS and other required certificates, and are hot selling in Europe, Australia, Asia, and other areas.

OCOM has a professional team including marketing, R&D, quality control, production and sales service. The management members have worked in the FORTUNE 500 companies as senior managers for many years. All of the sales have more than 5 years' experience, which helps us to meet and exceed the customers' satisfaction.

OCOM has been sticking to the quality system of ISO9001:2008. We make strictly IQC, IPQC and OQC inspection per industrial standard. All the products must pass 24-48 hours aging test before shipment. Some designated models can have as long as 24 months warranty. We have the mass production capabilities that produce thousands of printers and scanners a week. Based on our strong capacity, the normal lead time for main products is about 3 to 7 days even for bulk order.

"Integrity based, Strive for excellence, Win-win cooperation". We would like to establish stable and reliable partnerships with customers all over the world. OEM/ODM is welcome.

